

Quick-release kit

The quick-release kit comes with a set of quick-releases to make folding and disassembling your trike into a quick and easy job. The kit consists of:



2 x 12mm quick-release axles.

These are installed in place of the 12mm axle bolts. Remove the finger nut from the end of the quick-release bolt. Slide the quick-release bolt into the hub from the outside, in exactly the same manner as you would the regular 12mm axle. When the bolt has been slid into the kingpost, screw the finger nut back onto the end of the bolt, and tighten the quick-release lever.

NOTE: The decorative hub cap that is supplied with the standard axles does not fit with the quick-release axle.



2 x 6mm front boom quick-releases

These are installed in place of the 2 - 6mm bolts that clamp the boom into place. Remove the 6mm bolts from the frame using a 5mm hex key. Slide the quick-release into the hole where the bolt was, and thread the quick-release into the frame to adjust its tightness. Make sure that the aluminium spacer on the quick-release sits down in the hole where the head of the bolt used to be. **These quick-releases should not be installed in the back of the main frame.**



2 x 6mm mudguard quick-releases

These replace the 2 bolts that hold the mudguards in place. Remove the old countersunk bolts using a 4mm hex key. Slide the quick-releases into the mudguard brackets and then thread them into the captive nuts in the kingposts. Screw them down to adjust the quick-release tension. You do not need to use the aluminium cap that normally covers the top of the kingpost. **These quick-releases should not be installed in the back of the main frame.**

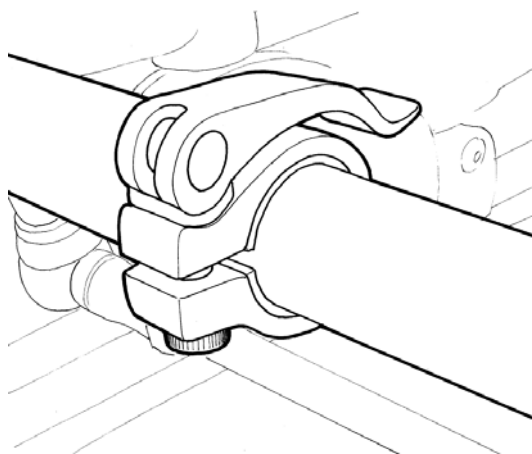

2 x quick-release handlebar clamps

These replace the handlebar clamps which are installed on your trike. To remove the old clamps, loosen the clamp bolts with a 5mm hex key, and then pull them from the end of the centre handlebar. The quick-release handlebar clamps are pushed into place, with the quick-release lever located behind the handlebar, with the slot in the clamp roughly lined up with the slot in the centre handlebar.